

REVISIONS		
REV.	DESCRIPTION	DATE
1	FIRST ISSUE	28/01/2009

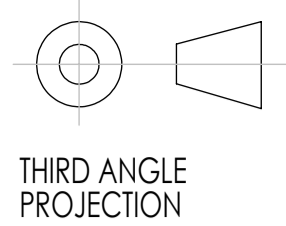

THIRD ANGLE PROJECTION

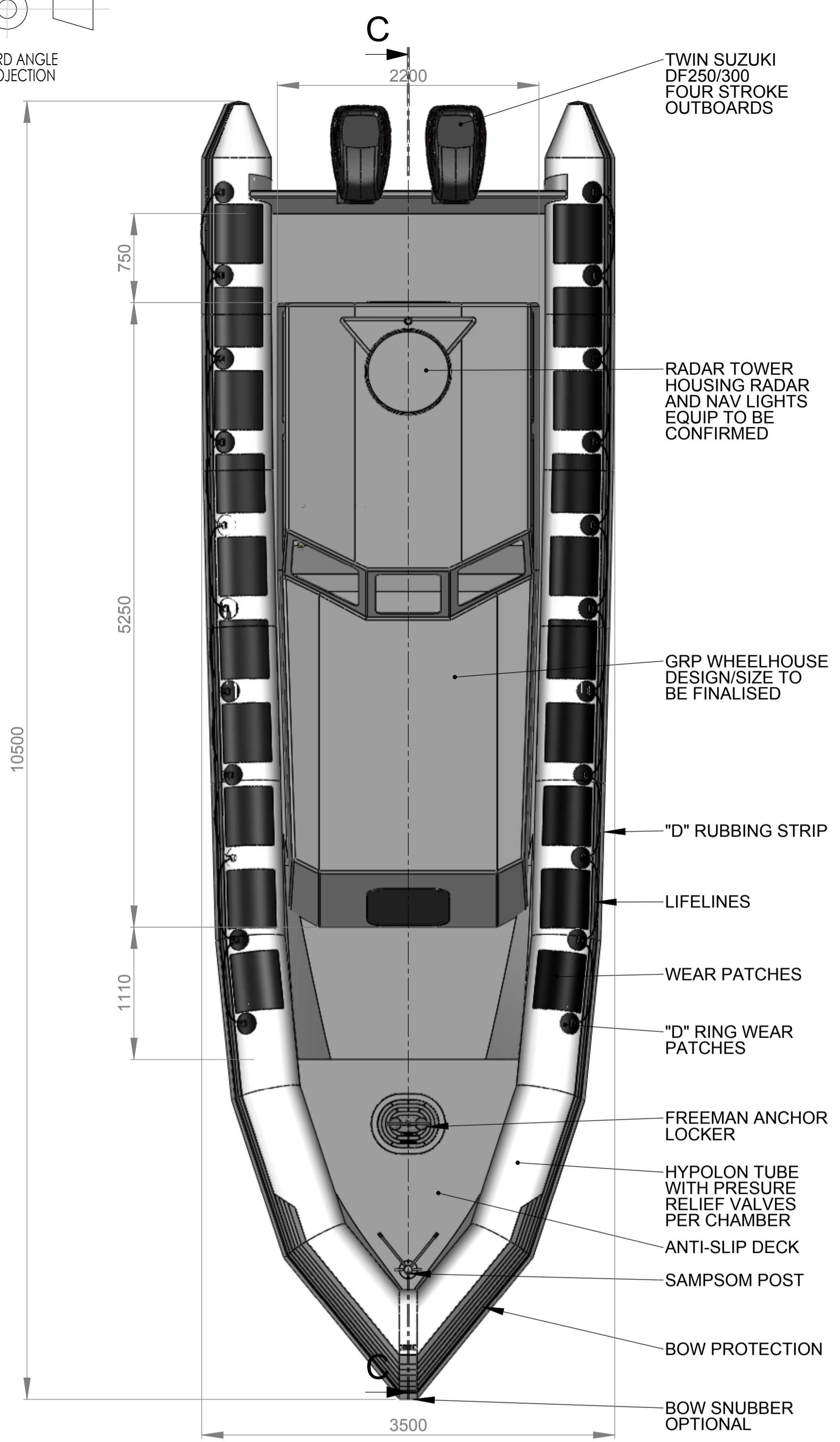

SECTION C-C

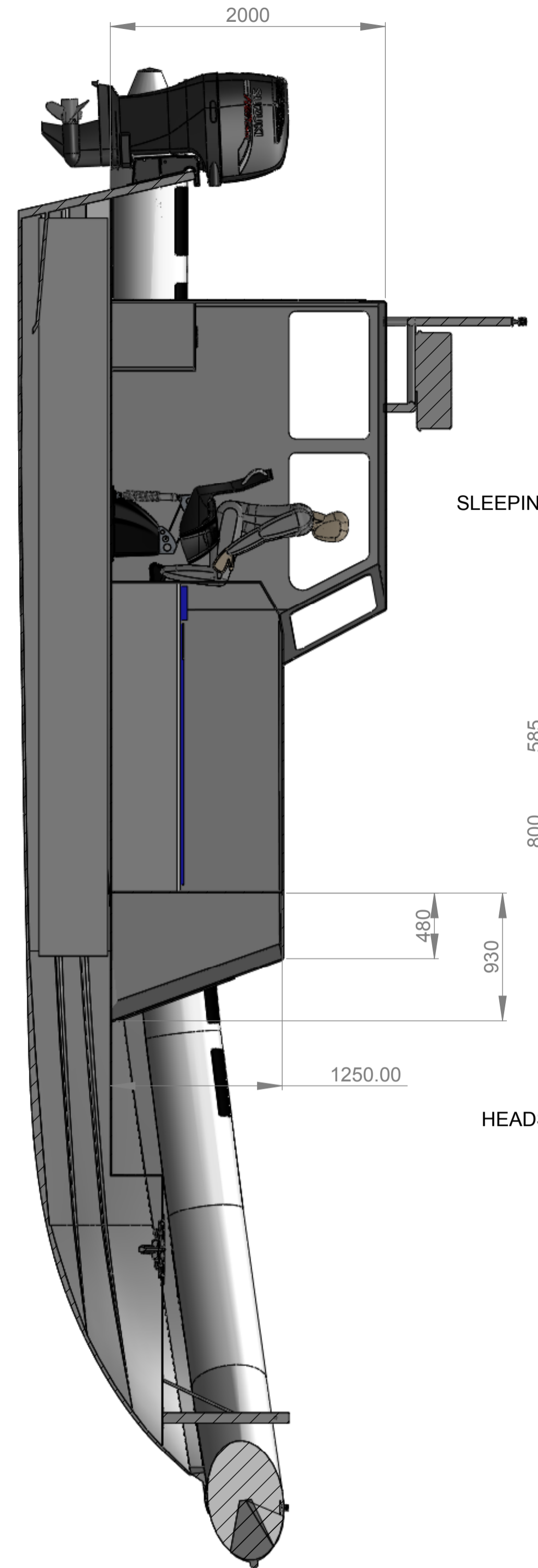

10.5m CABIN

SECTION B-B

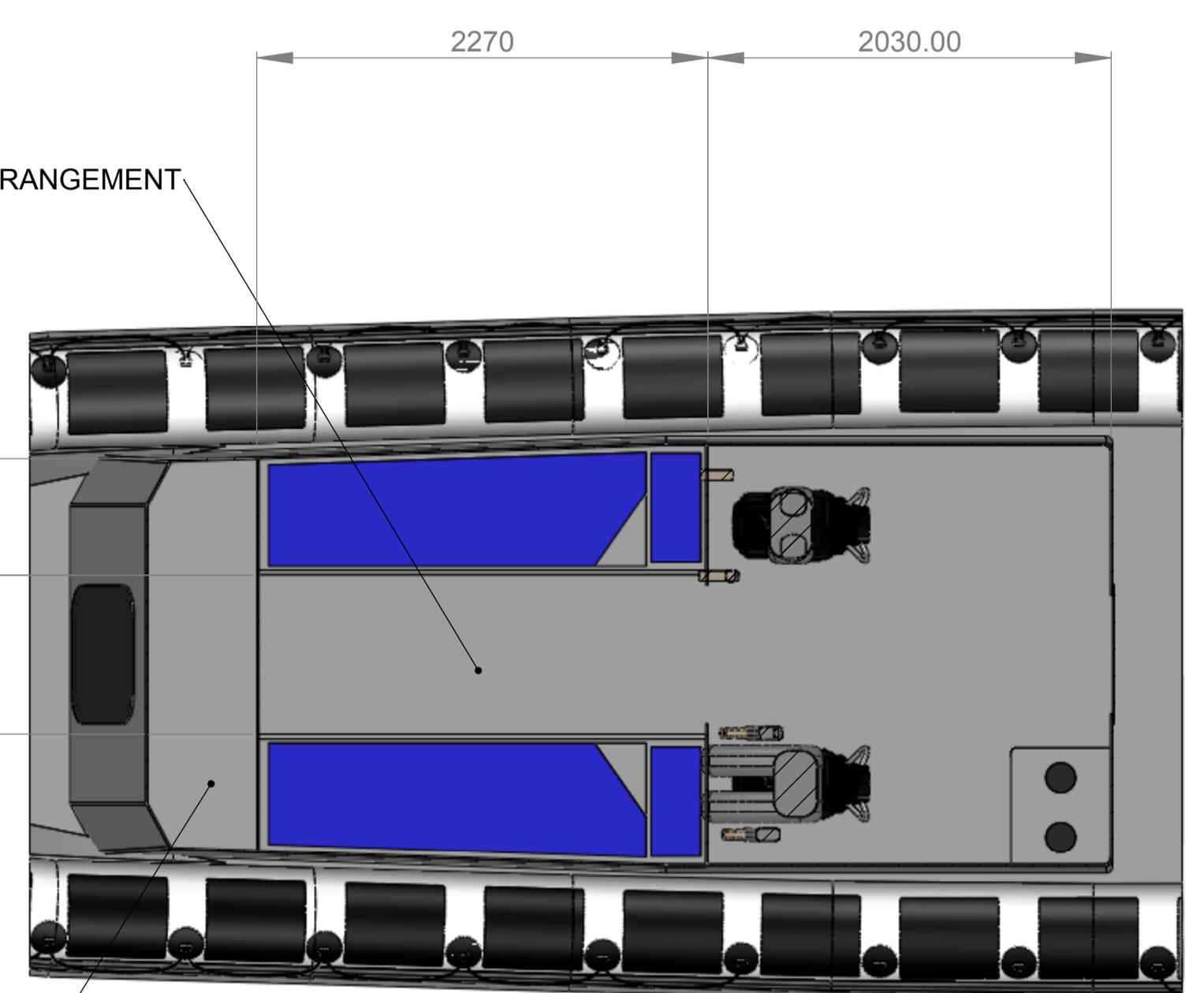

SECTION A-A

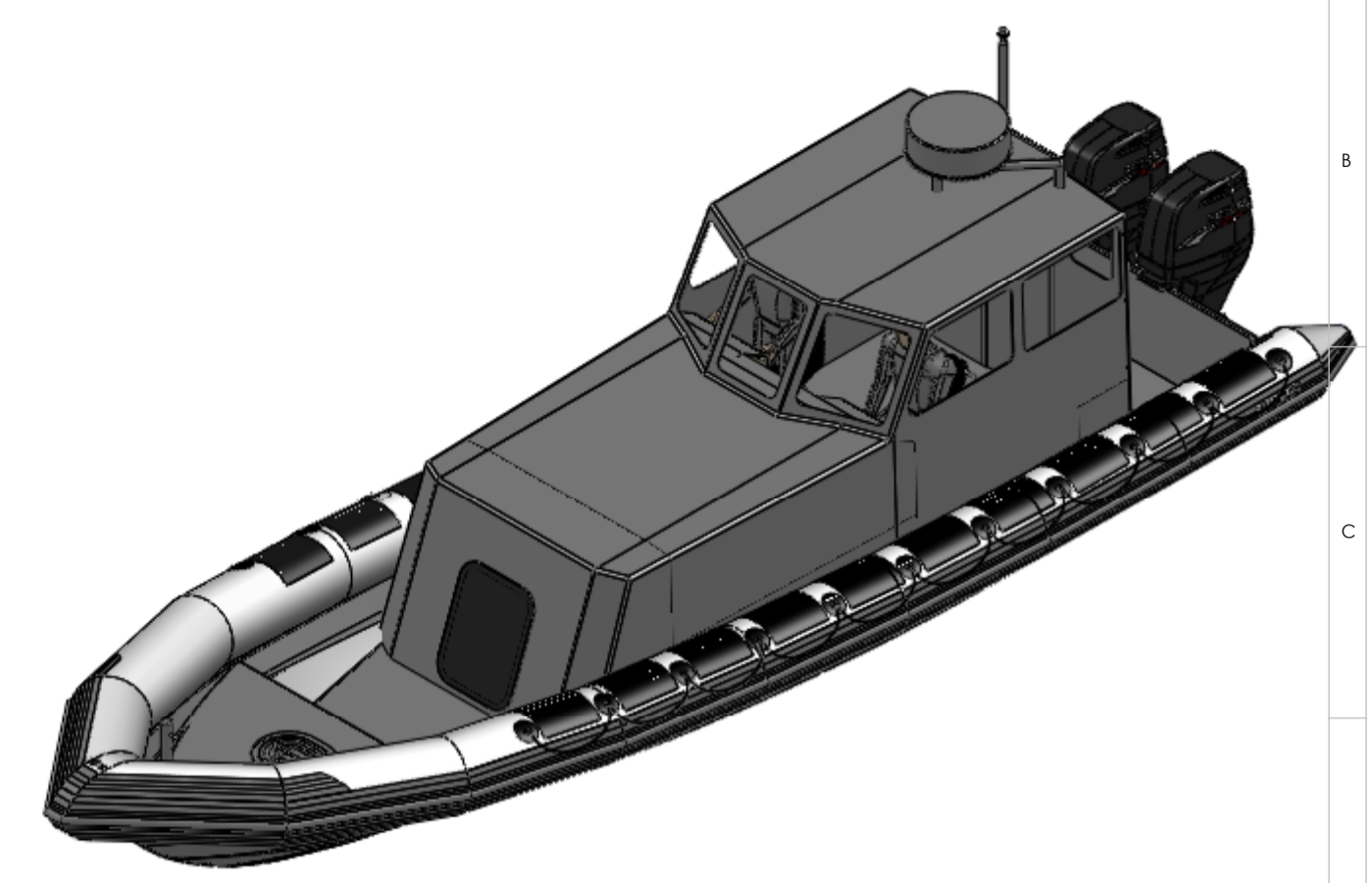
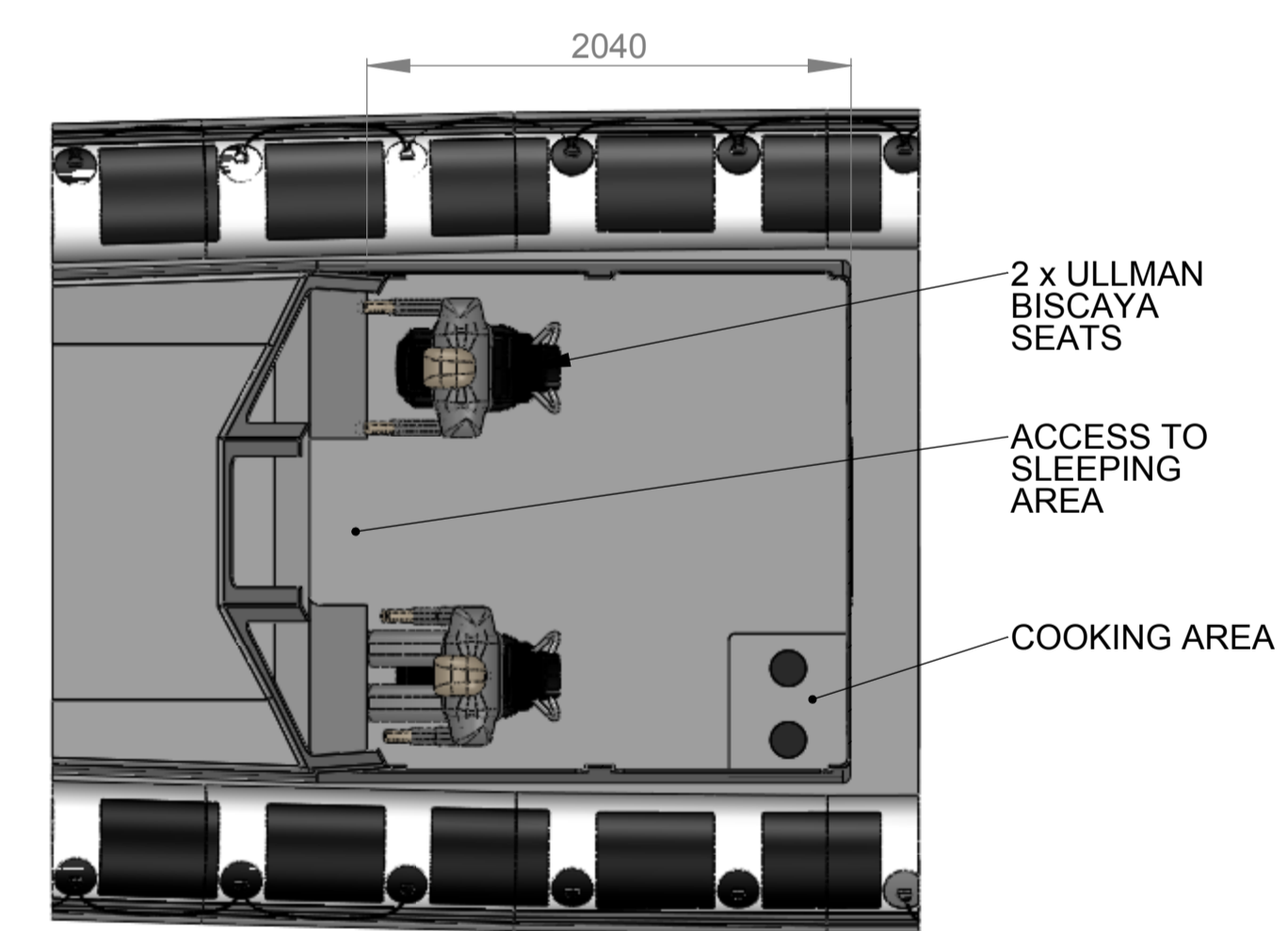

NOTES

- HULL - ALUMINIUM
- DECK (ANTI-SLIP) - TBA
- UPHOLSTERY - TBA
- POD SEATS - TBA
- BENCH SEAT - N/A
- CONSOLE - N/A
- WHEELHOUSE - TBA
- TUBE - TBA
- RUB STRIP - TBA
- WEAR PADS - TBA
- "D" RING TUBE PADS - TBA
- ROPE - TBA
- GRAB HANDLE - TBA
- BOW SNUBBER - TBA
- SELF RIGHTING BAG - N/A
- LOGO - TBA
- ALL TUBE WORK IS POLISHED 316 GRADE STAINLESS STEEL
- TWIN STAINLESS STEEL FUEL TANK MOUNTED UNDER DECK, 225 GALLONS (500 Ltrs)
- UNDER DECK TRUNKING FOR CABLES
- EXTRA'S - TBA
- TRAILER - TBA

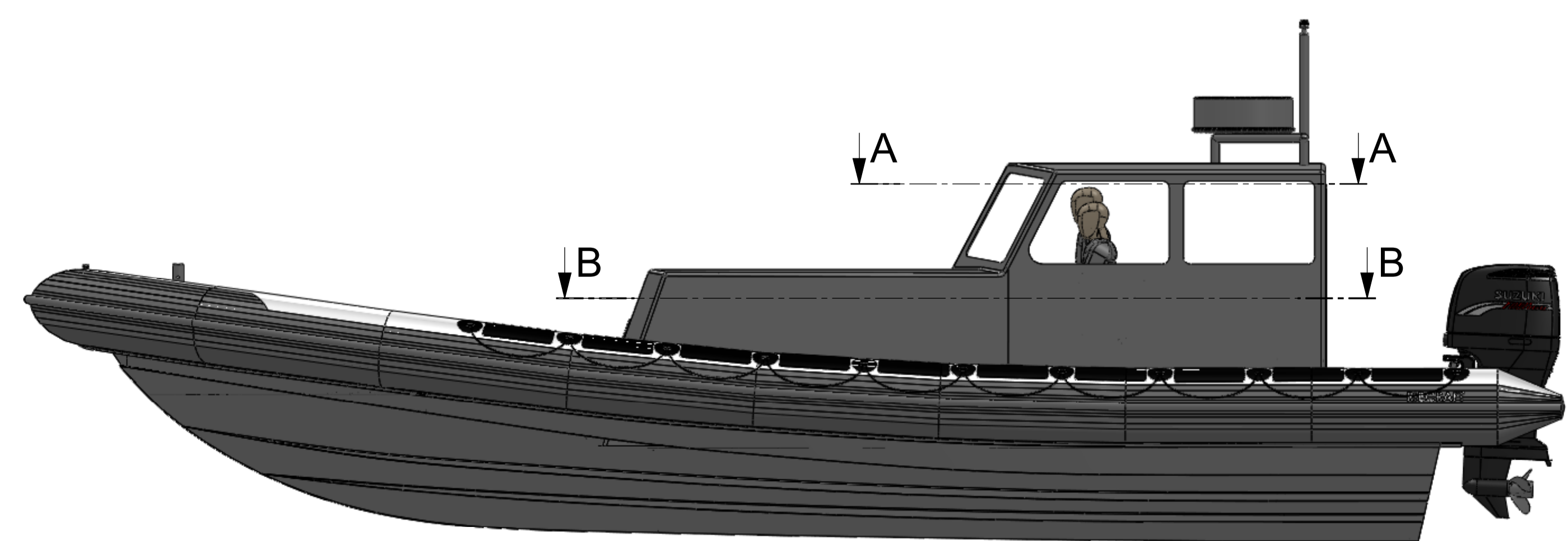
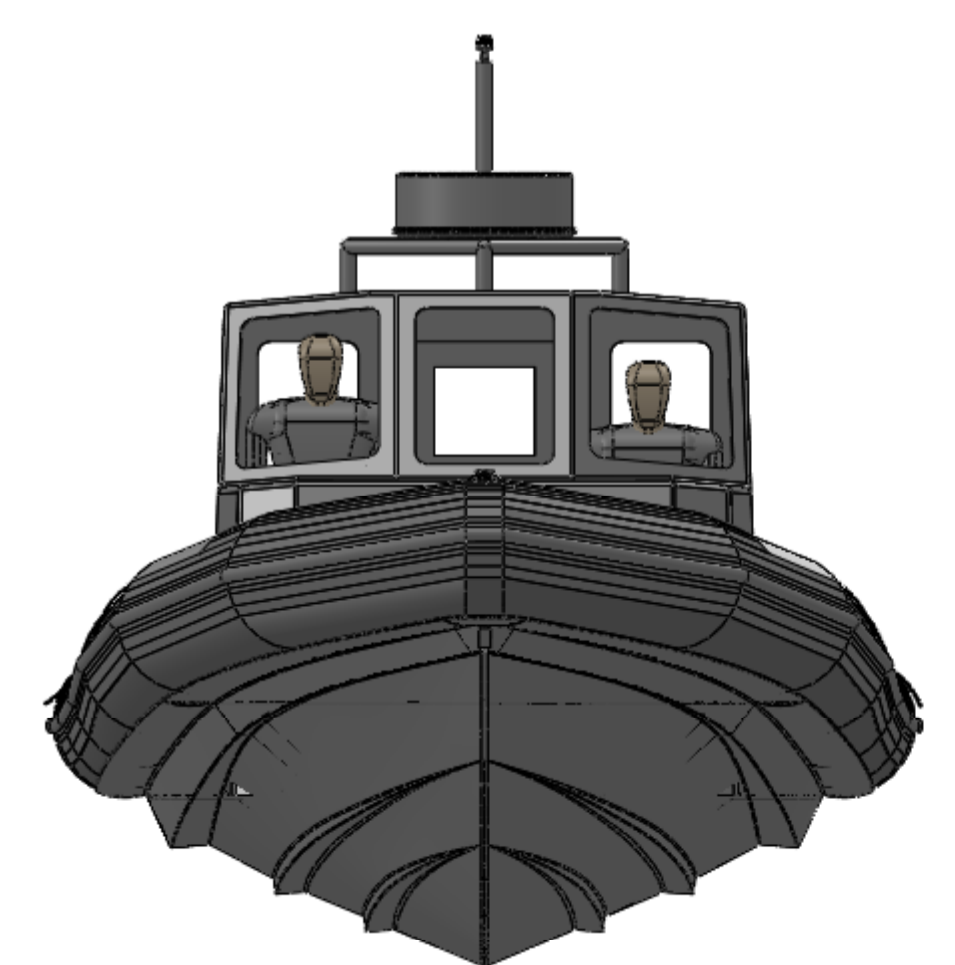

NAME	DATE	EDWARD CLOSE, HOUNDSTONE BUSINESS PARK YEovil, SOMeSET, UK, BA22 8RU Tel : 01935 411 846, Web : www.ribcraft.co.uk email : sales@ribcraft.co.uk
DRAWN	CDG	
CHECKED	APPVD	

GENERAL TOLERANCES UNLESS STATED OTHERWISE. ALL DIMENSIONS ARE IN MILLIMETERS. LINEAR : ± 0.5mm ANGULAR : ± 5 DEGREES SURFACE FINISH : -	TITLE : 10.5m CABIN	TENDER No. :	CRAFT : 10.5M	SHEET 1 OF 1
	MASS : -	STOCK CODE : -		
			SCALE: 1:30	DRG NO : RCL00033

DO NOT SCALE IF IN DOUBT, ASK